

Transmitter	
Turning Circle:	100%
Steering Expo:	-15
Brake E.P.:	90%
Throttle Expo:	+15

Speed Control	
E.S.C. Type:	LRP FLOW
E.S.C. Settings:	S.W. Ver.

Motor	
Motor:	Reedy Sonic 13.5

Gearing	
Gearing:	21 / 81

Notes: 32 degrees timing

Notes:

Front	Alignment	Rear
5.2mm	<b>Ride Height</b>	5.2mm
1.5	<b>Camber</b>	1.5
6	<b>Caster</b>	N/A
N/A	<b>Rear Hub Toe</b>	0
0.5+	<b>Toe (Total)</b>	3
0	<b>Hex Spacing</b>	0
1mm	<b>Wheelbase</b>	1mm
7b	<b>Steering Bellcrank</b>	N/A
2b	<b>Steering Link</b>	N/A
black 0 spacing	<b>Bumpsteer</b>	N/A

Suspension Geometry		
2b	<b>Shock Position</b>	3b
v3	<b>Camber Link Position</b>	v3a
black+4mm	<b>Inner Ball &amp; Shims</b>	black+2mm
silver+1mm	<b>Outer Ball &amp; Shims</b>	silver+2mm
3b offset	<b>FWD Arm Mount</b>	3b
2mm	<b>FWD Mount Shim</b>	0
3b offset	<b>RWD Arm Mount</b>	3b offset
1mm	<b>RWD Mount Shims</b>	0.5mm
6.5	<b>Droop</b>	6
blue	<b>Anti-Roll Bar</b>	silver

Shocks		
35	<b>Oil</b>	35
losi 57	<b>Piston</b>	losi 57
0	<b>Rebound</b>	0
green	<b>Spring</b>	silver

Differentials		
spool	<b>Type</b>	gear
	<b>Setting</b>	1k
a	<b>Cam Holder</b>	a
teeth at top	<b>Belt Tension Number</b>	teeth at top

Tires		
sorex 28	<b>Type</b>	sorex
	<b>Tire Diameter</b>	
jb	<b>Insert &amp; Wheel</b>	jb
LRP 2 Full	<b>Additive &amp; Amount</b>	LRP2 Full

Notes: additive for 25 mins

Chassis	
Chassis:	WORLDS #31279
Top Plate:	Cut at each end

Battery Placement	
Placement:	Back

Notes:

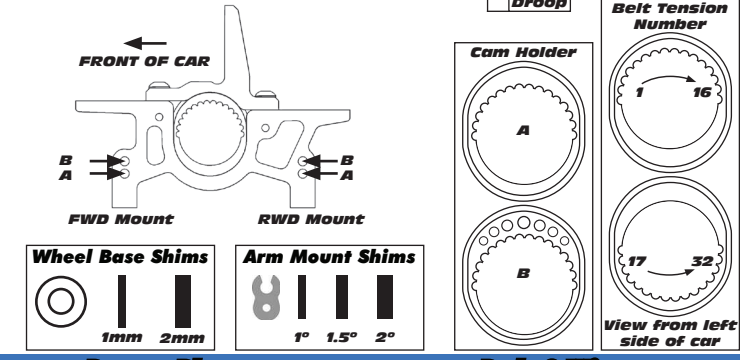
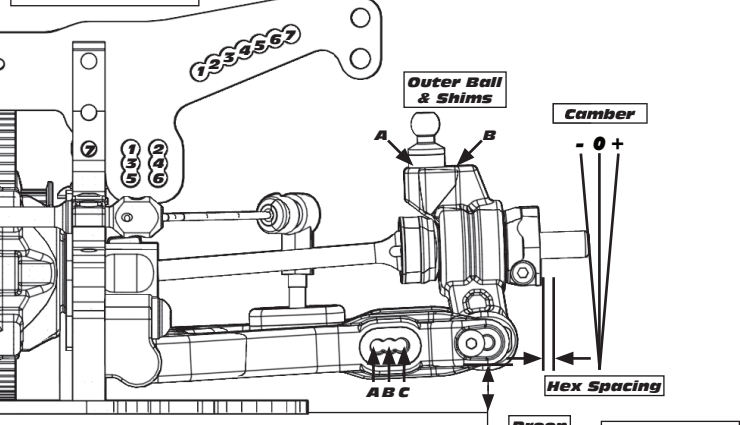
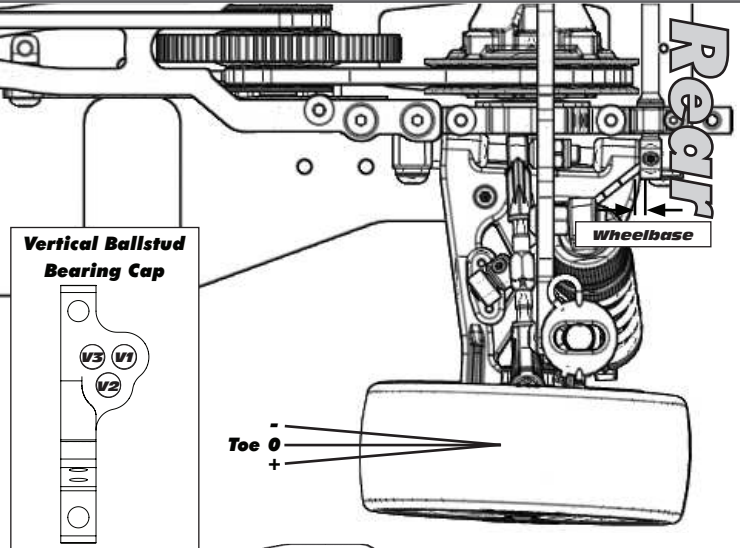

Body & Wing	
Body:	Protoform Speed 6
Wing:	Lightweight wing

Notes: